

TURBO AIR LAPPER MODEL: UTR-30



Technical Specifications

Type.....	Turbine Air Motor Lapper	Dimension.....	Ø28 x 200mm
Max Speed at no load.....	40,000spm	Noise at no load.....	84dB(A)
Stroke.....	0.3mm	Sound Pressure.....	76dB(A)
Air Pressure.....	6.2 bar	Weight.....	220g
Air Consumption.....	0.05 m ³ /min	Oil Regulation.....	2~3 drop/hour

Standard Components

- | | |
|-------------------------|------------------------------|
| 1. Air Hose | 2. Muffler |
| 3. Adapter | 4. Quick Joint |
| 5. Hex Key | 6. Ø3 & 1mm slot tool holder |
| 7. 1mm slot tool holder | 8. Adjustable tool holder |

Optional:

1. 3.2 x 13mm tool holder
2. 6.3 x 13mm tool holder

General Setup:

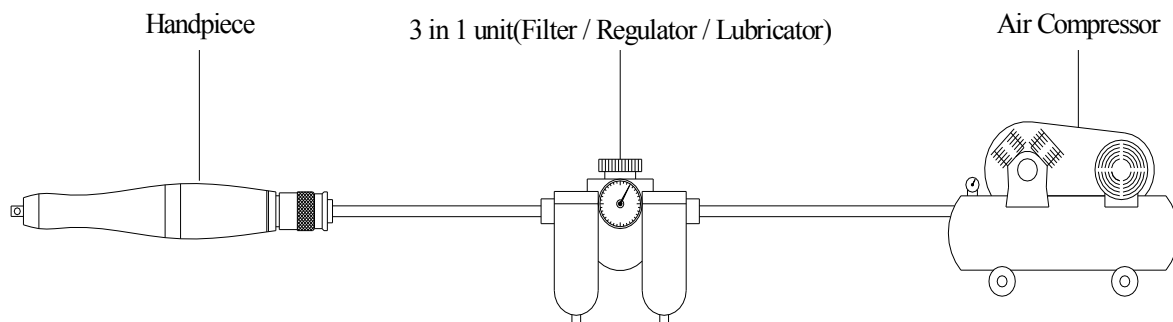

Rules for Long Lasting and Performance Utilization:

Air Tools and the 3-in-1 units, Filter/Regulator and Lubricator

1. In order to remain the air tools in the best performance and prolong its life time, it is advisable to equip with the 3-in-1 unit; Filter/Regulator & Lubricator.
2. Before starting, use few drop of turbine oil at the tip of the air hose for lubrication.
3. Set the **pressure controller (regulator) at 90psi**, which is recommended air pressure for all air tools. Higher pressure is not necessary and will shorten the tools' life or cause damage to the tools.
4. Turn on the tool and let it runs freely (at no load) for few second before operation or before working on the work-piece.
5. Keep the compressed air in dry condition at all time to prevent rust that destroys the tools. Avoid moistness or water gets inside the hand-piece by checking the filter frequently. The air filter on the 3-in-1 unit is used for drying out water. Always check that the air filter tube does not contain over 80% water. It is advisable that the filter is drained daily.
6. Use only a good grade of light oil, it is important not to use thick and greasy oil.
7. Set the oil controller at **2 drops per hour for lubrication**. During the weekend or a long period vacation, increase to 4 to 5 drops per hour, leave the tool running free for few minutes before turning off.
8. Keep the unit away from fire, corrosion, moisture.

*****If the Lubricator is not being used, it is recommended to put a few drops of oil per every 2 to 3 hours of operation.***

Operation Conditions; Start & Stop device

- The on/off switch is ring throttle action, which is located in the proximity of the handgrip so that it can be activated without releasing your hand from the handgrip; turn the throttle counter clock wise to open and turn clock wise to close.
- Before connecting to the air supply, make sure that the throttle is in the off position.
- The switch will not automatically move to the "off" position when the air supply is connected. Before connecting or turning on the air supply, make sure that the switch is at the "off" position.